

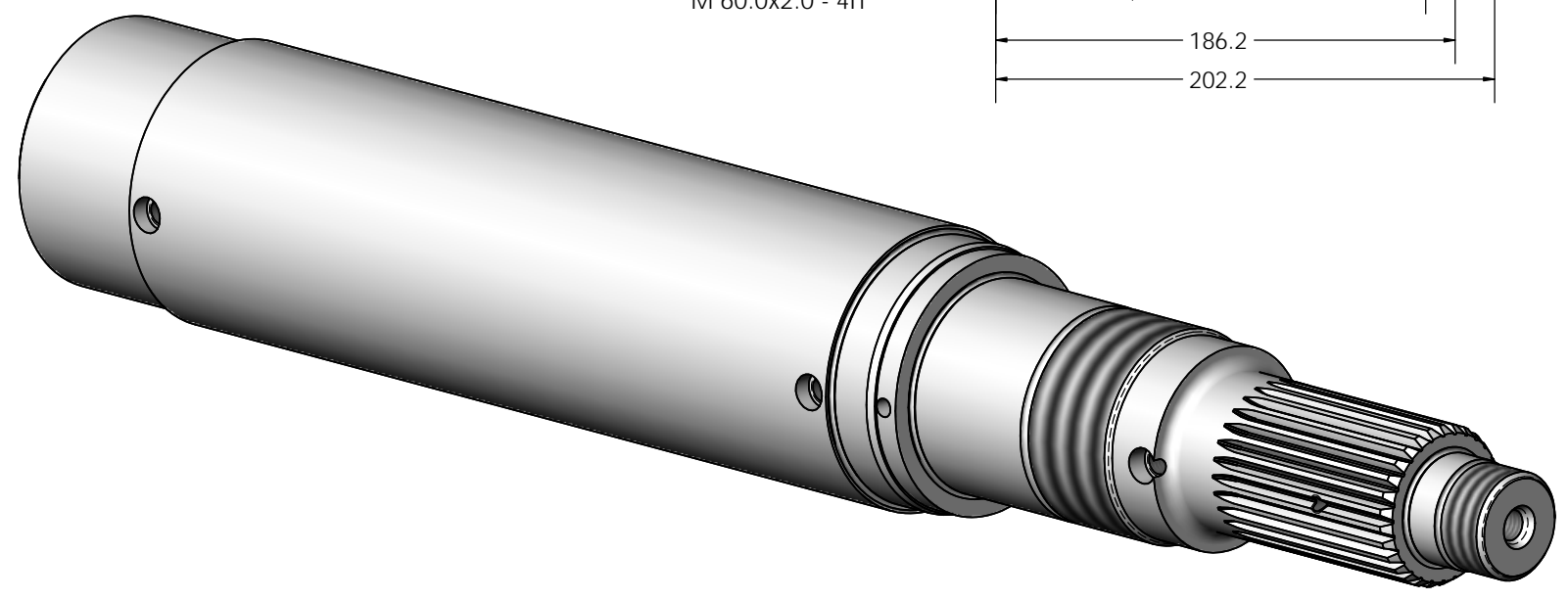

REVISIONS			
REV	DESCRIPTION	APPROVAL	
		ENGG	DATE

External Involute Spline Data	
All spline characteristics are product significant	
Flat Root Side Fit	
Number of teeth	29
Module	1.50
Pressure angle	30°
Base diameter	37.672
Pitch diameter	43.5 $\sqrt{0.051}$ A - B $\blacklozenge$
Major diameter	44.60-44.85 REF.
TIF diameter, MAX	41.69
Minor diameter	40.40-40.65
Circular tooth thickness	
MAX. Effective	2.272
MIN. Effective, REF.	2.209
MAX. Actual, REF.	2.234
MIN. Actual	2.171
Pin diameter	2.667
Measurement over pin	47.007-47.109

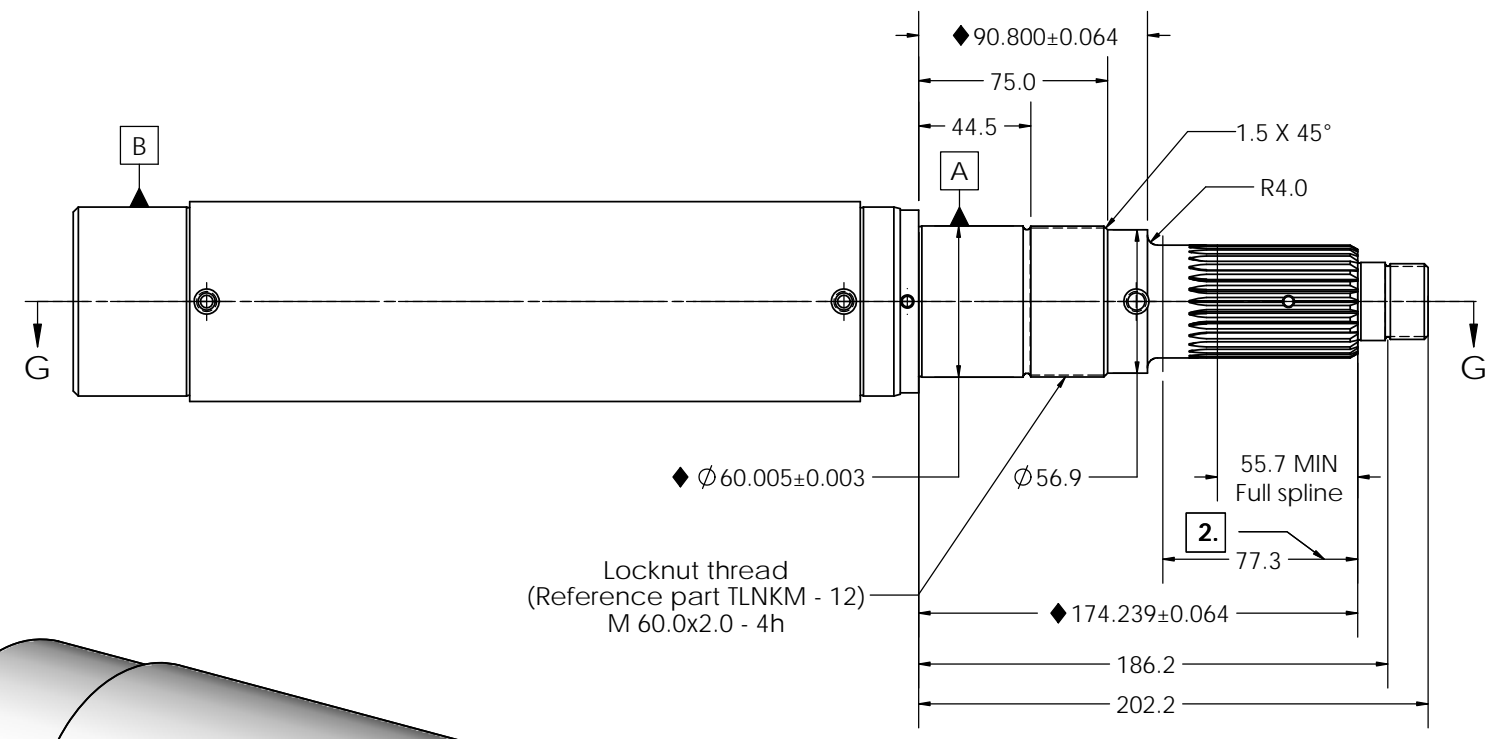
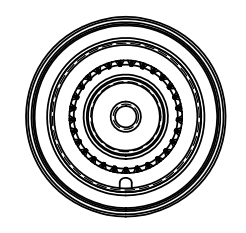
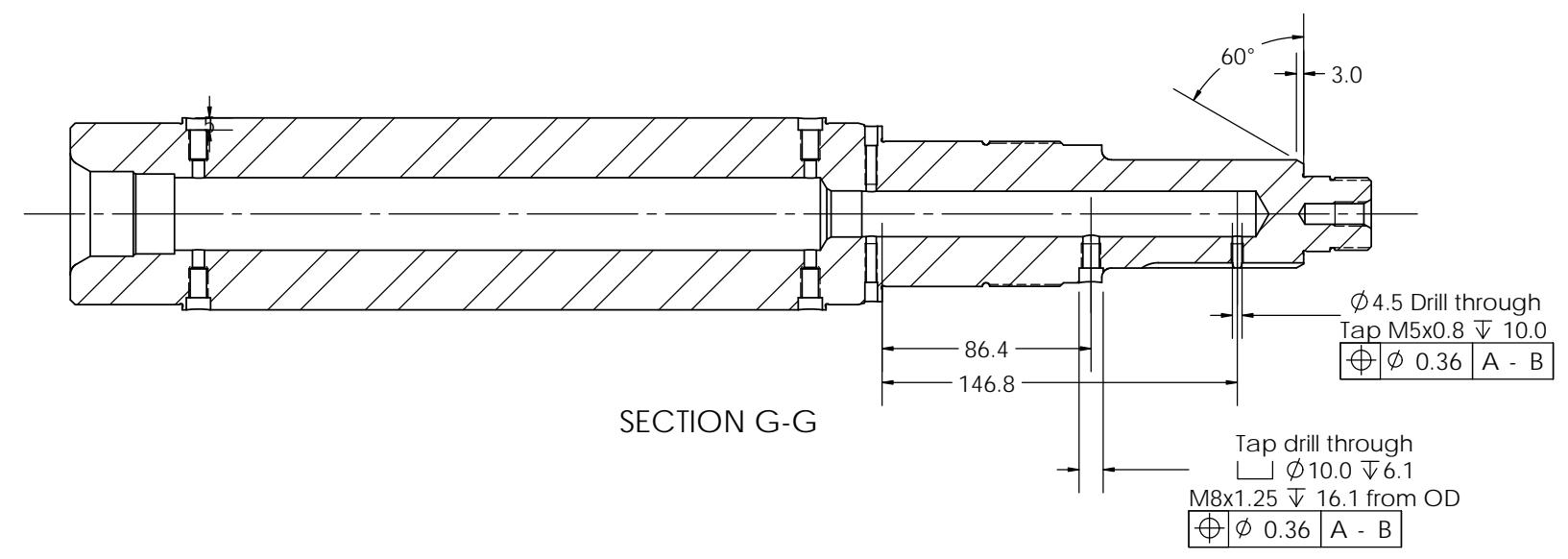

- 1. Material:** Steel Alloy 8620, HRc 15 MIN., IAW AMS 6274, AMS 6276, AMS 6277, ASTM A322 or ASTM A321.
- 2. Heat treatment:** Carburize noted surface per AMS2759/7 class 2, type 1. Effective case depth shall be 0.25 to 0.5 and a surface hardness on HRc 58-64. Case depth shall be determined at spline pitch diameter. Core hardness in noted area shall be HRc 21 minimum. Parts shall be magnetic particle inspected to IAW ASTM EI444. No cracks seams or laps allowed. AMS 2759/7 section 3.7 time limit can be increased to 6 hrs.
- 3. Hardness testing:** Per AMS 2759 section 4.3.1 can be performed on sample coupon representative of actual part.
- 4. Surface finish:** Unless otherwise specified, machined surfaces to a surface finish of 3.2 micro-meter or better.
- 5.  $\blacklozenge$  - represents a key characteristic.**

DIMENSIONAL TOLERANCES UNLESS SPECIFIED			RELEASED BY PROJ. MGR. TO	TITLE		DRAWN BY		DATE	CHECKED BY	DATE	
TYPE	DECIMAL	FRACTIONAL	INTERNAL SHOP	ROTOR SHAFT		19Nov2025		19Nov2025	19Nov2025		
LINEAR	x ±0.3 xx ±0.13		QUOTE								
ANGULAR	± 0.5		PILOT RUN								
ALL DIM. IN MILLIMETERS UNLESS SPECIFIED			ADVANCE BUY	CUSTOMER							
THREAD CLASS: 6g/6H (2A/2B)			BUY TOOLING	MATERIAL:	Steel Alloy 8620;		TREATMENT				
REMOVE BURRS AND BREAK EDGES: ISO 13715			RELEASED TO PRODUCTION BY ENGINEERING	15 HRc min.							
SCALE: NTS			WEIGHT (GRAM):	13529.24		DWG. NO		088-0250			
			REVISION	0		SHEET		2		OF 2	