

4

3

2

1

AS CAST

- AS PER GEOMETRY OF 30028295_AS_CAST.STP
- CASTING TOLERANCES MUST CONFORM TO ISO 8062 GRADE CT9.
- DRAWING INFORMATION ALWAYS VALID OVER STEP FILE.
- USE A SANS SERIF FONT FOR ARTICLE/PART NUMBER AND MANUFACTURER LABEL [TR-MMY].

REV. 4	CHANGE NOTE	ECO 0674	ECO DES. siso080	DATE 20260115	APPR. daep038
MODIFIED INNER FILLET RADIUS FROM 3MM TO 0.5MM					

.070M

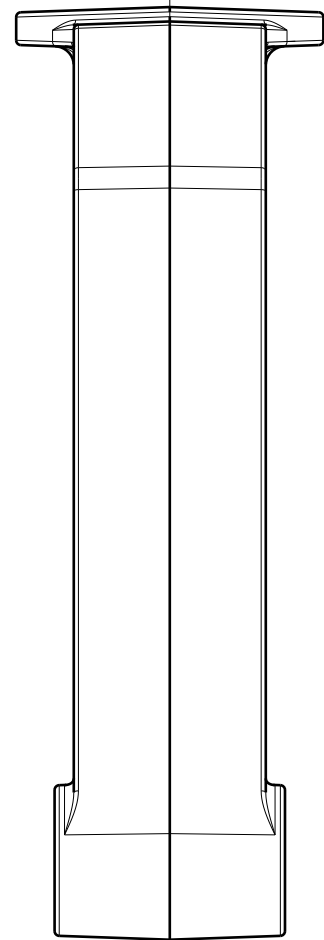
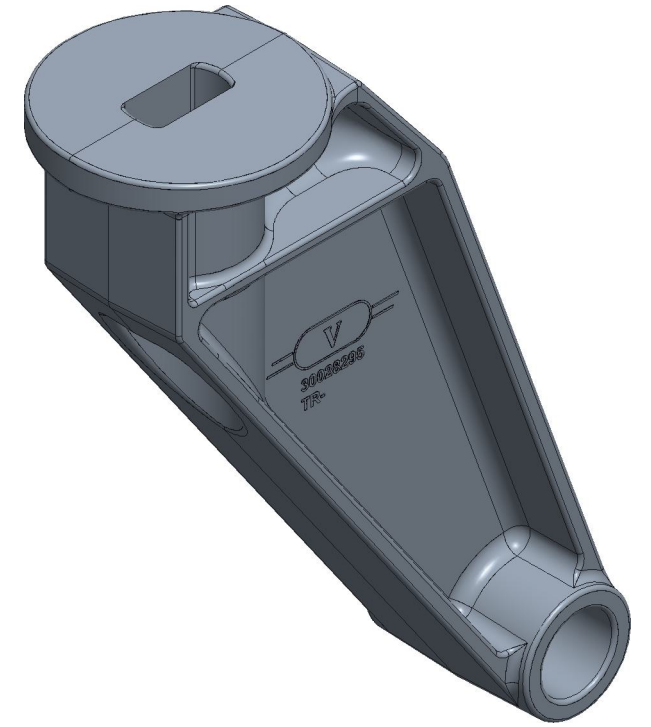
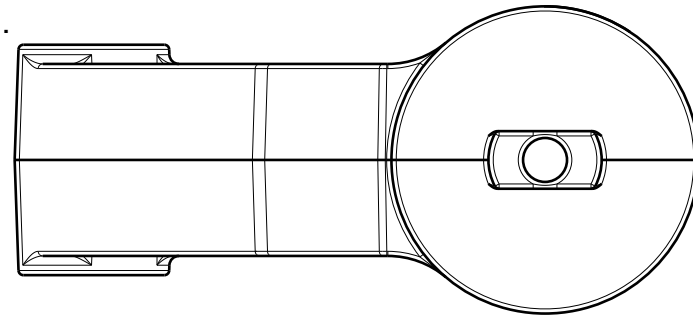

Ø 8.000

24.287

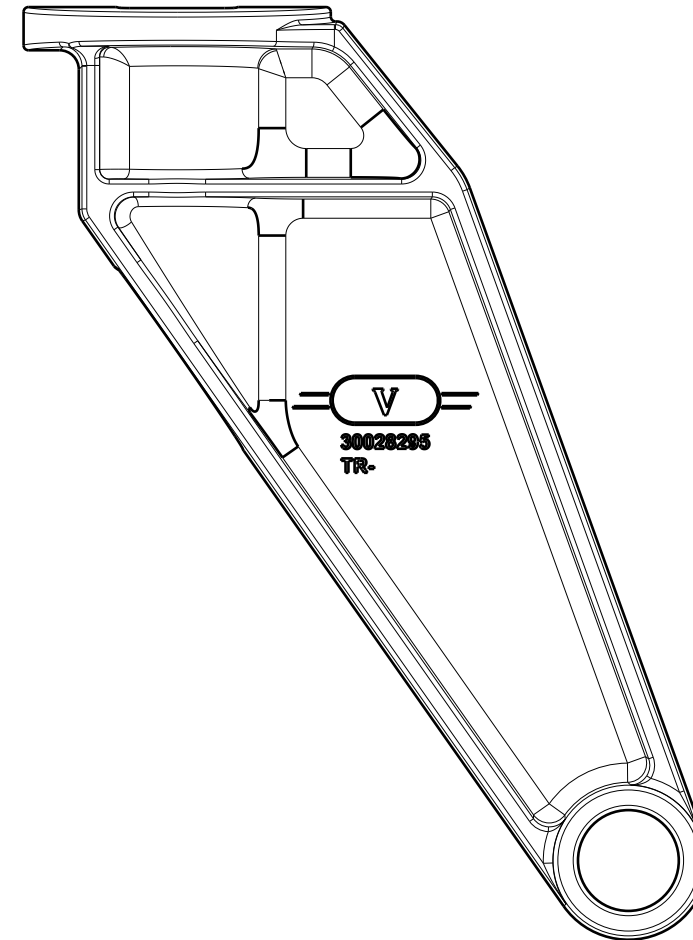
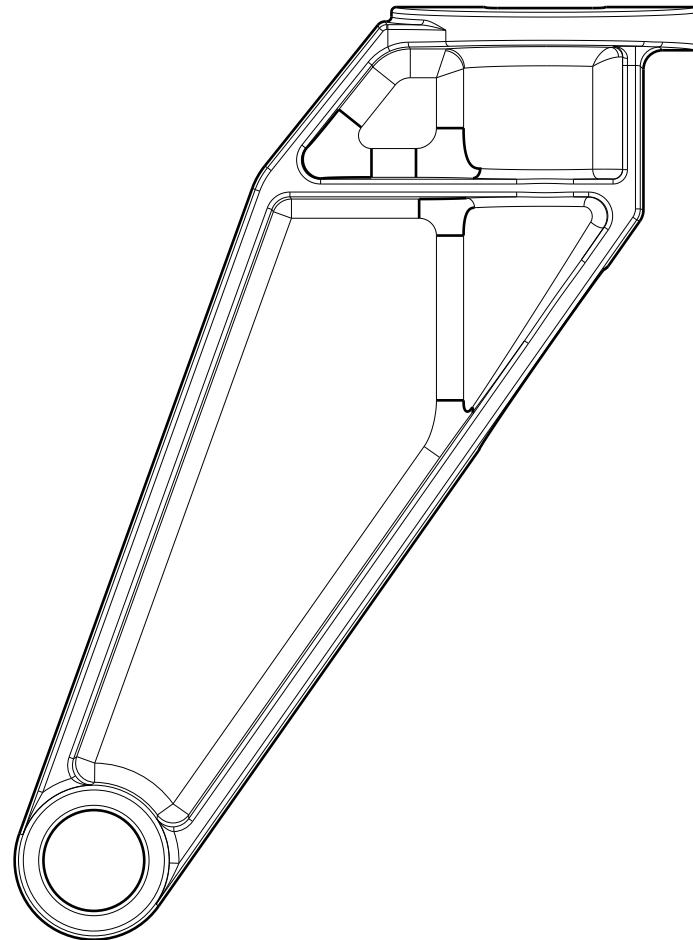

17.813

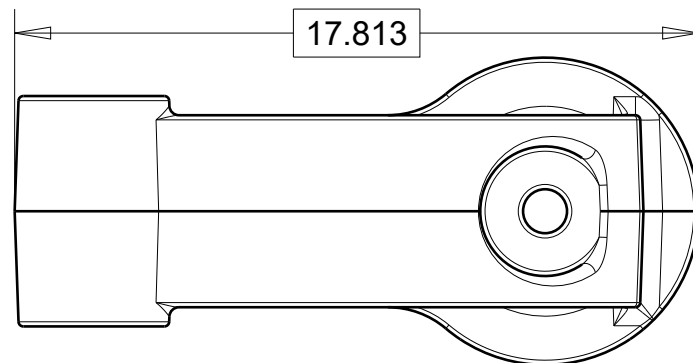

MATERIAL DUCTILE IRON, 80-55-06		MATERIAL TYPE CAST, MACHINED		VIEW ⊕		CATEGORY CAST		C/NECO 0674	
DESIGNER SISO080	EXAMINER daep038	RELEASED 20250618 siso080	EST. WEIGHT 88.2 lbmass	TOLERANCE UNLESS OTHERWISE SPECIFIED STD. UNIT INCHES X.X = ±0.1 X.XX = ±0.02 X.XXX = ±0.01 ANGLES = ±1°		DATE 2025-05-06	SR -	SCALE 1/5	REV. 4
PAINT COLOUR RED		DESCRIPTION SUPPORT WHEEL		STATE Change Pend		NUFO X	REV. 4	SIZE B	SHEET 1/2
		WING WALKING CASTOR, CAST		PART NO. 30028295					

4

3

2

1

AS MACHINED

- BREAK ALL SHARP EDGES.
- PAINT/POWDER COAT IAW VII STANDARD 01-007 - PAINT SPECIFICATIONS.
- ONLY MASK THE SURFACES INDICATED.
- APPLY CORROSIONX® OR EQUIVALENT RUST INHIBITOR TO UNPAINTED SURFACES FOLLOWING POWDER COAT/PAINT.
- MUST CHECK DRAIN HOLE NOT BLOCKED BY PAINT.
- DIMENSIONS ARE BEFORE PAINT.

REV. 4	CHANGE NOTE	ECO 0674	ECO DES. siso080	DATE 20260115	APPR. daep038
MODIFIED INNER FILLET RADIUS FROM 3MM TO 0.5MM					

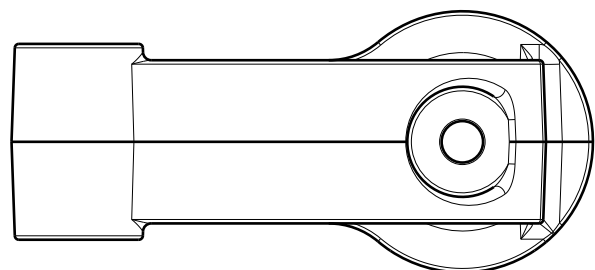
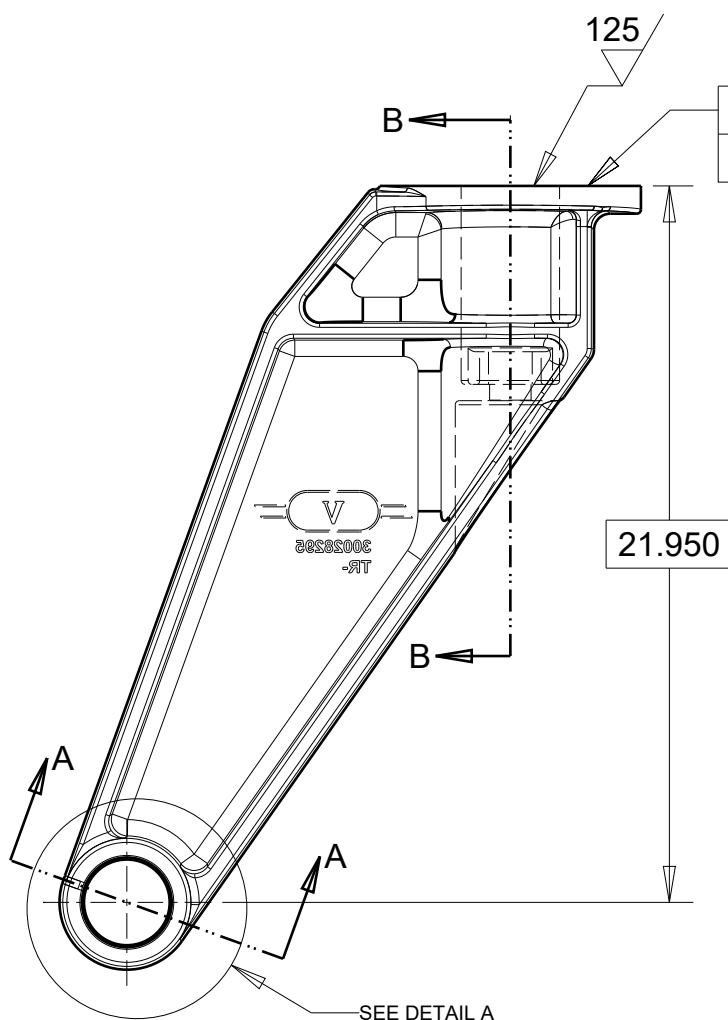
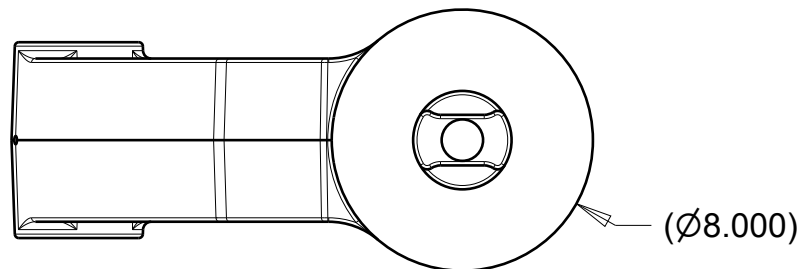

1/4-28 UNF - 2B TAP ∇ 0.511
 #3 DRILL (0.213) THRU -(1) HOLE
 *TAP GREASE HOLES AFTER PAINT

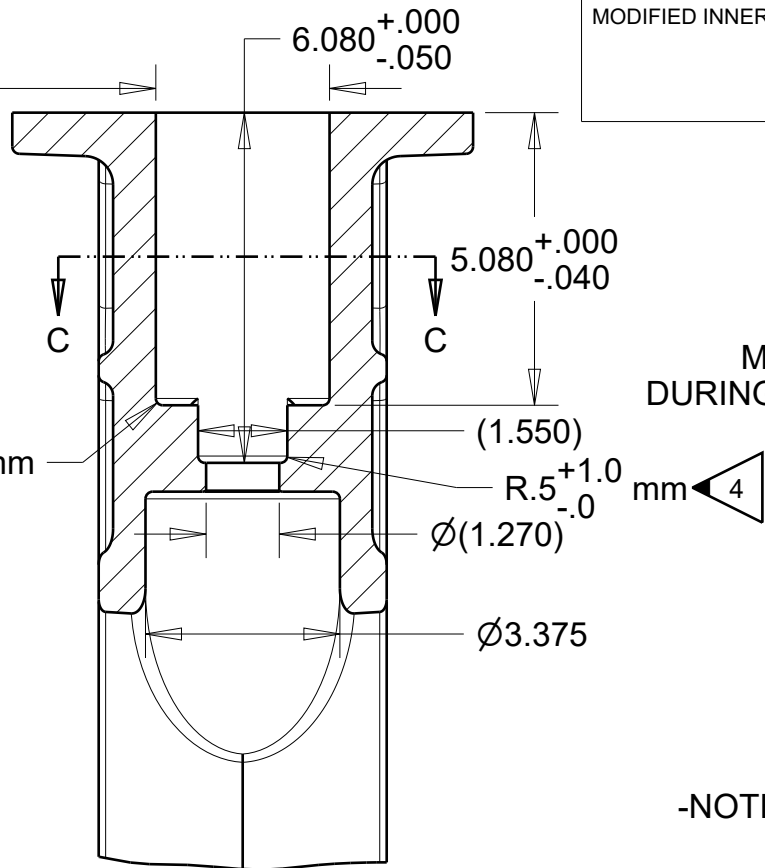
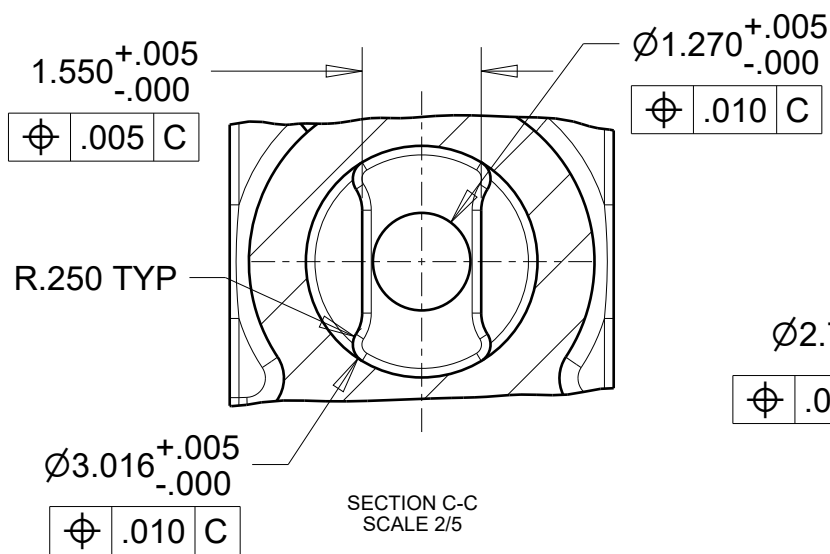
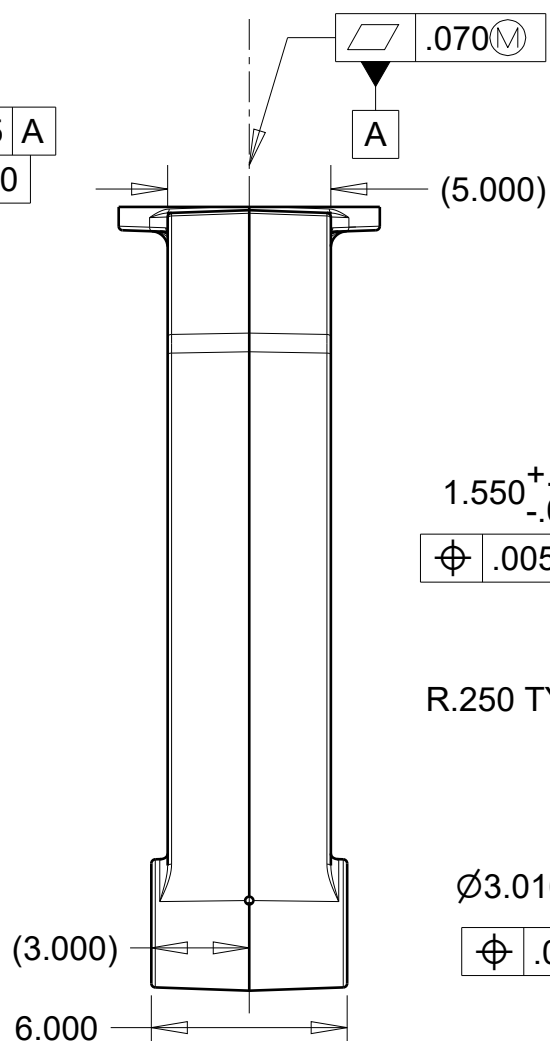
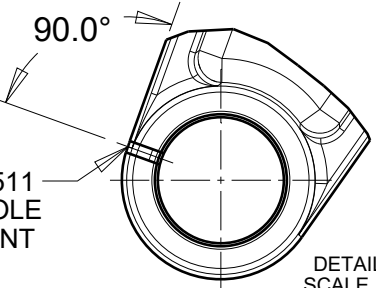

MASK SURFACE BORE
DURING POWDER COATING

-NOTE PAINTED AND UNPAINTED SURFACES.
-ONLY PIN HOLES ARE MASKED

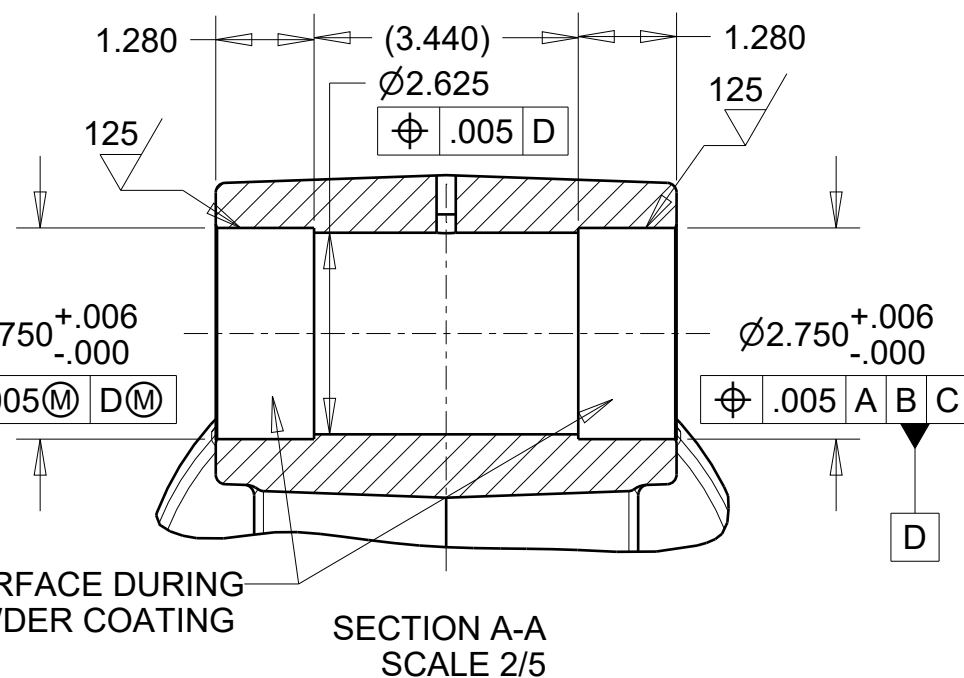

MASK SURFACE DURING
POWDER COATING

MATERIAL DUCTILE IRON, 80-55-06		MATERIAL TYPE CAST, MACHINED		CATEGORY CAST		C/NECO 0674	
DESIGNER SISO080	EXAMINER daep038	RELEASED 20250618 siso080	EST. WEIGHT 88.2 lbmass	VIEW ⊕	DATE 2025-05-06	SR -	SCALE 17/100
PAINT COLOUR RED		DESCRIPTION SUPPORT WHEEL		TOLERANCE UNLESS OTHERWISE SPECIFIED STD. UNIT INCHES X.X = ±0.1 X.XX = ±0.02 X.XXX = ±0.01 ANGLES = ±1°		STATE Change Pend	REV. SIZE 4 B
		WING WALKING CASTOR, CAST		PART NO. 30028295		SHEET 2/2	

