

REV	DATE	DESCRIPTION	BY
A	2015-04-27	INITIAL RELEASE	SLR

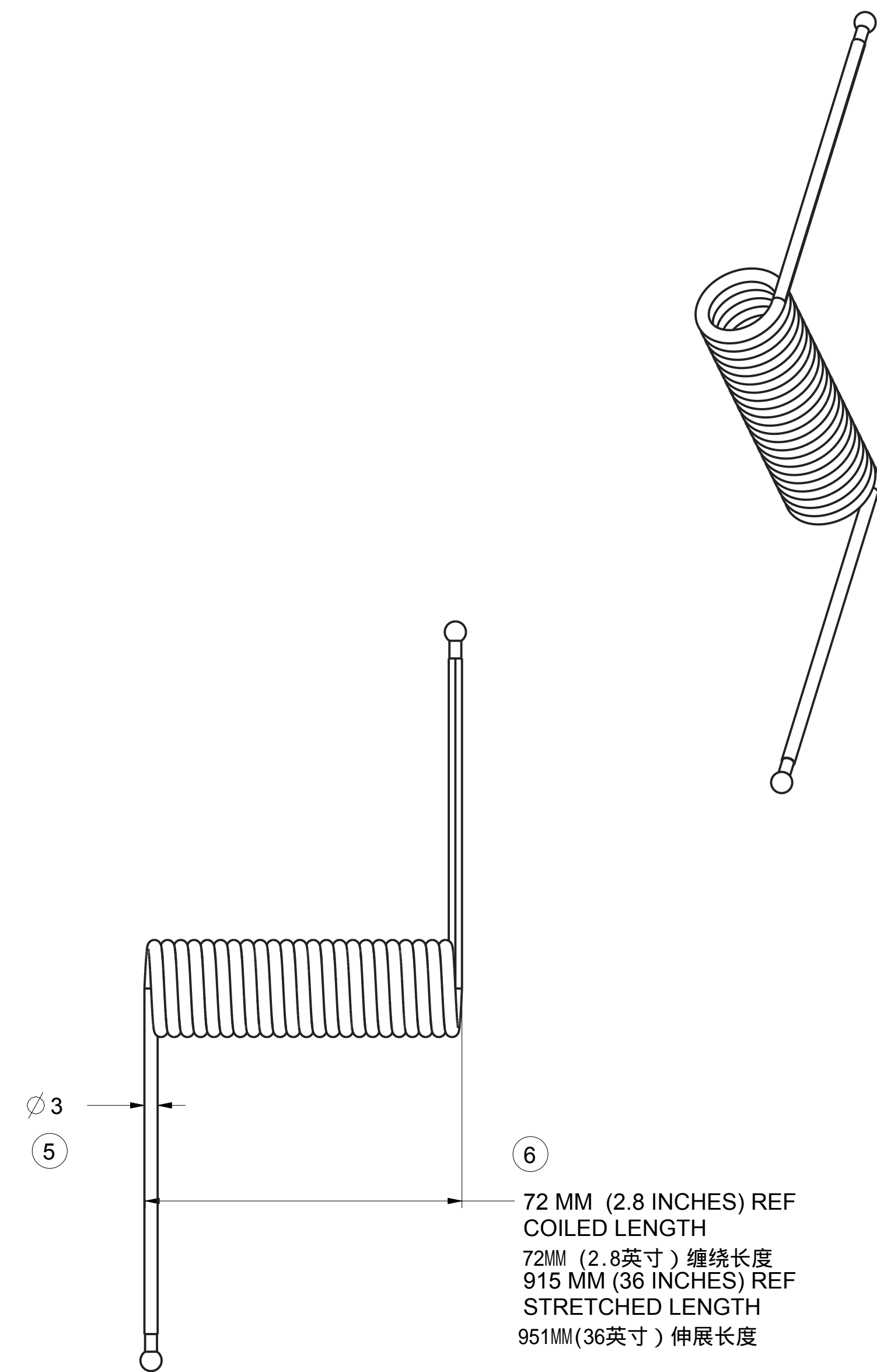
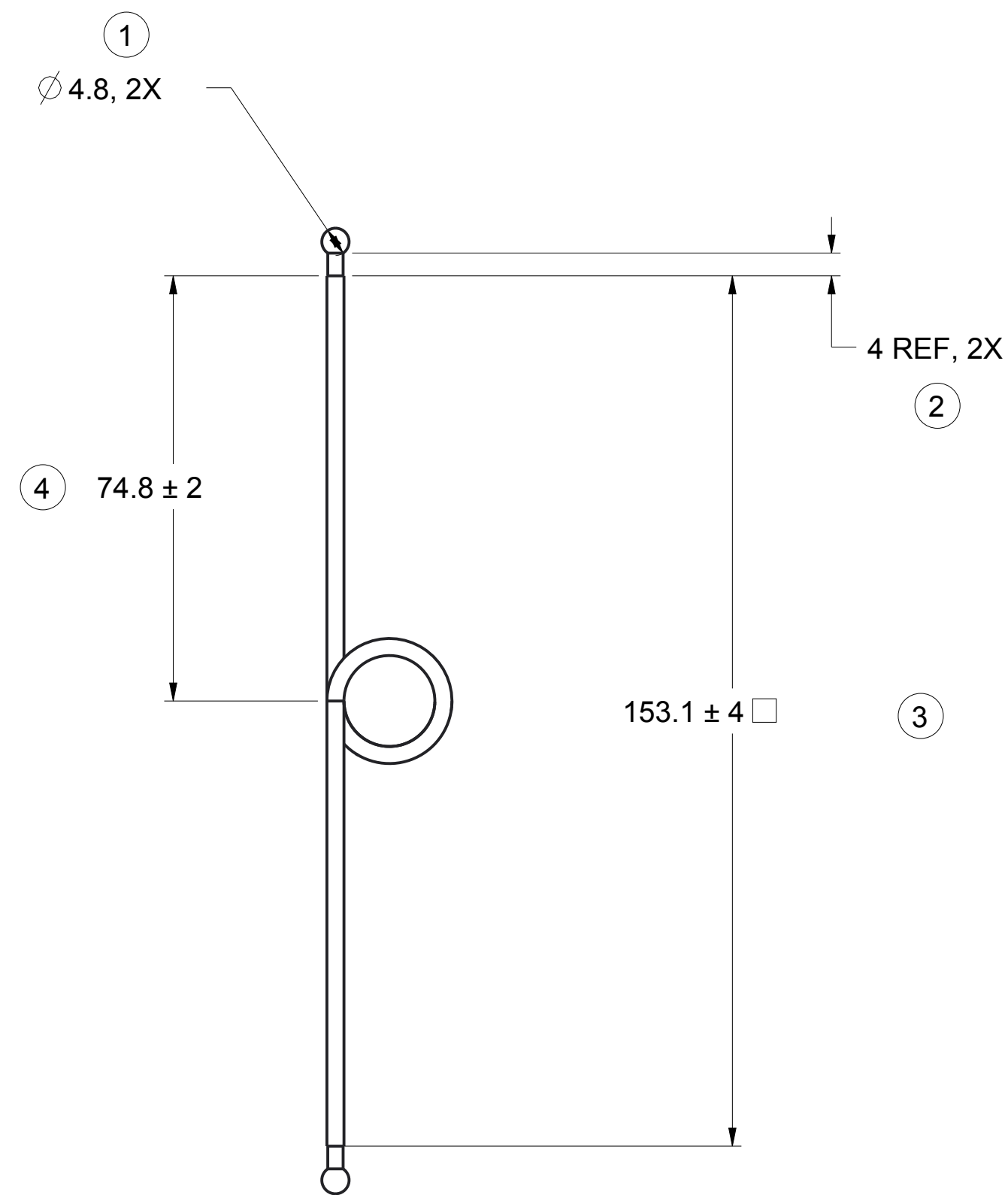

NOTES:

- GENERAL
  - APPLICABLE STANDARDS/SPECIFICATIONS. 使用标准: ASME Y14.5M-1994尺寸和公差  
ASME Y14.5M-1994 DIMENSIONS AND TOLERANCES.
  - REMAINDER OF DIMENSIONS VIA 3D CAD DATA. 其余尺寸按照3D CAD 图纸
  - MOLD DESIGN AND MOLD MATERIALS TO BE APPROVED BY ALPHA SECURITY PRODUCTS ENGINEERING.  
MOLD DESIGN ENGINEERING DRAWINGS AND 3D DATA TO BE PROVIDED TO ALPHA SECURITY PRODUCTS ENGINEERING UPON COMPLETION OF TOOL BUILD. 模具设计和模具材料要通过ALPHA确认 模具完成后, 将设计图纸和3D数据提供给ALPHA
  - PROTECTIVE WRAP OR PACKAGING IS REQUIRED TO PREVENT DAMAGE DURING SHIPMENT AND HANDLING UNLESS OTHERWISE APPROVED BY ALPHA SECURITY PRODUCTS.  
除非通过ALPHA批准, 在运输及搬运过程中要求有保护套或包装来避免破坏
- MARKING (IF APPLICABLE)
  - N/A 无标记
- CABLE SPECIFICATIONS 线规格
  - CABLE: 1/16" 7X7 STRAND GALVANIZED AIRCRAFT CABLE 电缆: 1/16" 7x7股 镀锌航空钢丝绳
  - CABLE JACKET MATERIAL: 1/8" MAX BLACK VINYL 线外壳材料: 最大1/8"黑色乙烯基
  - CABLE/JACKET COILED DURING THE EXTRUSION PROCESS 挤压过程中, 线/外壳缠绕成圈
  - CABLE END BALL SHANK: 0.190" DIAMETER T302/304 STAINLESS STEEL, FORMED TO CABLE VIA HYDROFORM PROCESS  
线端滚珠丝杆: 0.190" 直径 T302/304不锈钢, 液压成型过程形成电缆
- FINISH 表面处理
  - TEXTURE: N/A 皮纹: 无
  - POLISH: N/A 抛光: 无
- SUPPLIER QUALITY ASSURANCE PROVISIONS
  - PART QUALIFICATION: THE SUPPLIER SHALL PROVIDE FIRST ARTICLE INSPECTION (FAI) IN ENGLISH WITH AT LEAST 5 FIRST SAMPLES WHICH ARE REPRESENTATIVE OF PRODUCTION.
  - IF THE MATERIAL IS POLYCARBONATE OR A POLYCARBONATE BLEND, MFI INCREASE PER MUST BE MAINTAINED WITHIN THE RESIN MANUFACTURERS RECOMMENDATION.  
REQUIRED TEST FREQUENCY IS PER "PROCESS CONTROL" FREQUENCY (MINIMUM OF ONCE PER DAY).  
MFI REPORT SHOULD BE INCLUDED IN THE FAI FOR QUALIFICATION
  - CRITICAL DIMENSIONS (WITH BOX SYMBOL) MUST BE INSPECTED BY 32 SAMPLES WITH CPK>1.5 FOR QUALIFICATION.

零件承认: 供应商需提交英语格式的首件测试报告, 至少取5个代表量产产品的样品进行测试  
如果材料为PC或PC混合物, 那么熔体流动指数的增加必须在树脂制造商的建议下  
要求的测试频率是根据过程控制频率(至少每天一次), 熔体流动指数报告必须包含在首件测试报告中  
重要尺寸(箱子标志)必须是在CPK大于1.5的条件下测试32件样品

DESIGNER	ENG
PRODUCT ENGINEER	ENG
MFG ENGINEER	MFG
SCALE 1.000	DWG SIZE D
SHEET 1 OF 1	

LLD

<small>THIS DRAWING AND THE RELATED DATA FILES ARE THE CONFIDENTIAL PROPERTY OF CHECKPOINT SYSTEMS, INC. AND ITS ALPHA HIGH SECURITY DIVISION. THIS DRAWING AND THE RELATED DATA FILES MAY NOT BE, IN WHOLE OR IN PART, REPRODUCED, COPIED, PROVIDED TO OTHERS, OR USED IN ANY MANNER THAT IS DETRIMENTAL TO THE INTERESTS OF CHECKPOINT SYSTEMS, INC. AND WILL BE RETURNED OR DESTROYED UPON REQUEST BY CHECKPOINT SYSTEMS, INC. THE TERMS OF A NON-DISCLOSURE AGREEMENT WITH CHECKPOINT SYSTEMS, INC. APPLY TO THIS DRAWING AND THE RELATED DATA FILES.</small>		
PROJECT NAME	COMMON PART	
TITLE	COILED LANYARD W/ BALL SHANK ON BOTH ENDS	
DRAWING NO.	STATE	REVISION
C90041		