

C

存储前必须去除所有的油脂。
 可以用不同的螺帽,但是必须符合PEM CLS系列
 孔的规格必须正好适合螺帽

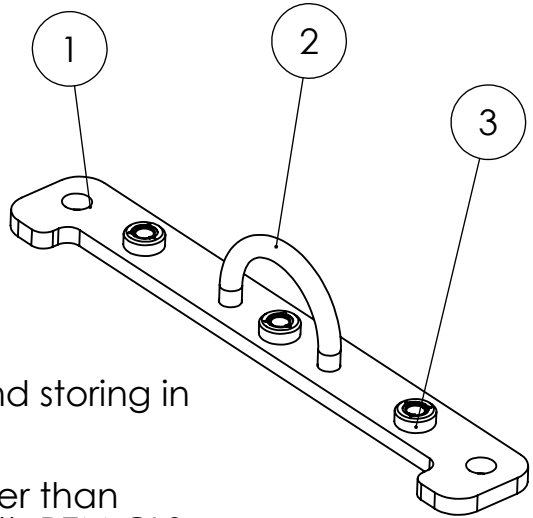

D

Part must be degreased before packing and storing in order to remove all oils, grease, films etc.

It is allowed to use different pressnuts supplier than specified. If done pressnuts must comply with PEM CLS Series, according to fastener material and min. dist. to edge. Hole size must be fitted to corresponding pressnut.

ITEM NO.	PART NUMBER	DESCRIPTION	QTY.
1	20063327	Chassis Absorb. Front	1
2	20063820	Hinge Shock Absorber	1
3	20063454	M6x1 Pressnut, PEM CLS Series	3

-	-	-	-
B	27.09.2012	Drawing to production doc, from letter to number. Geometry of hinge changed	MN

Rev. Date		Revision note				Rev. by	
YXLON YXLON International A/S Helgeshøj Alle 38 DK-2630 Taastrup Tel. +45 72 40 77 00 www.yxlon.com	Material	Type	Scale		1:2		
	Dimension	Group	Design by	MN	03.05.2012		
	Surface finish	Sheet	1 of 1	Format	A4		
	Pcs.	Title		Project / Cat.no.	100020		
			Drawing no.		20063326		
			Rev. no.		1		
Dimension without tolerance use DS 2768-mK							