

型号/Model	Z610JA32 (灰)
----------	--------------

1. 适用范围/General

本说明书适用于圆筒式永磁直流电机 Z610JA32 (灰) 型

This specification applies to cylindrical permanent-magnetic motors DC model

Z610DA32 (灰) 使用条件/Operating condition

	项目/Item	规格/Specification	条件·备注/Condition remark
2-1	额定电压 Rated voltage	1.5V DC	
2-2	额定负荷 Rated load	负载	见外形图 As specified in outline drawing
2-3	旋转方向 Rotation	CW, CCW (clockwise or anticlockwise)	
2-4	马达位置 Motor position	全方位 All position	
2-5	使用电压范围 Operating voltage	1.2~2.4V DC	
2-6	使用环境 Operating environment	-30~70°C, Ordinary Humidity	无水气凝结 No condensation of moisture
2-7	保存环境 Storage environment	-40~80°C, Ordinary Humidity	无水气凝结 No condensation of moisture

3. 测定条件/Measuring condition

	项目/Item	规格/Specification	条件·备注/Condition remark
3-1	温度 Temperature	20±2°C	
3-2	湿度 Humidity	(63%~67%) RH	
3-3	位置 Motor position	轴向水平 Motor shaft horizontal	将马达固定在试验台上 Lock the motor in a test fixture

所有数据都是在温度 20°C, 湿度 65%的条件下测得的。判定有异议时, 在温度 5~35°C、湿度 45~85%的范围内测试。

All data are based on the measurement under the temperature of 20°C and humidity 65%RH. however, the ranges of temperature 5~35°C and humidity 45~85%RH are to be applicable as long as no problems

4. 机械要求/Mechanical specification

	项目/Item	规格/Specification	条件·备注/Condition remark
4-1	结构 Configuration	见外形图 As specified in outline drawing	Outline drawing No: Z610JA32(灰)
4-2	外观 Appearance	不含有机机械损坏及不充分的浸蚀等。 There shall be no evidence of mechanical damage and shall not have inadequate corrosion and so on	目测 (容许范围根据样品外形) Visual examination (allowable extent is based on boundary sample)
4-3	轴向间隙 Shaft end play	0.05mm~0.3mm	

4-4	振子固定力 Holding strength of vibration weight	49N (5kgf) Min	
-----	--	----------------	--

5. 性能特征/Performance and characteristics

项目/Item	规格/Specification	条件·备注/Condition remark
5-1	额定转速 Rated speed	12000±1000rpm
5-2	额定电流 Rated current	≤40 mA Max
5-3	堵转电流 Stall current	100mA Max
5-4	起动电压 Starting voltage	0.8V DC Max
5-5	绝缘电阻 Insulation resistance	1MΩ Min
5-6	端子阻抗 Terminal resistance	14Ω (±20%)
	机械噪音 Mechanical noise	小于 50 分贝. A 计权 50db (A) Max

在额定电压、额定负载（振子）下。
At rated voltage and rated load (vibration weight).
背景噪音：不大于 28db. A 计权
Back ground noise 28db (A) Max
测试仪器：B&k
Measuring instruments: B&k
夹具重量：700g
Weight of jig:700g

5-7

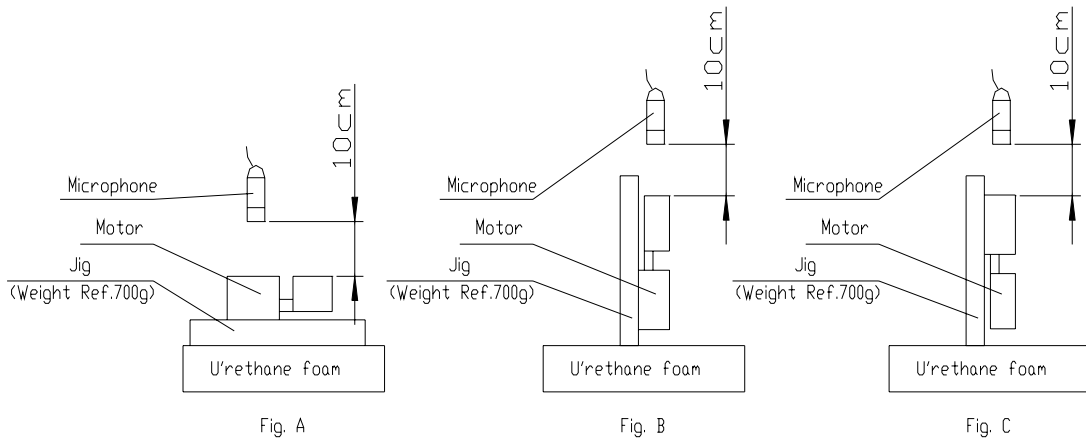

6. 可靠性/Reliability

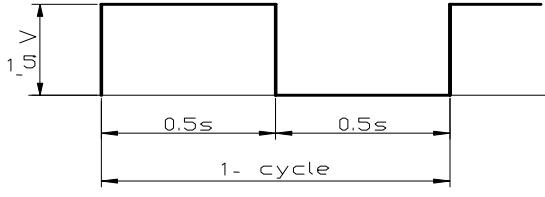
项目/Item		规格/Specification						判定标准/Judgment	
6-1	寿命 Life							<p>在常温常湿下放置 2h 后, 马达应符合项 7-1 的要求。 After 2 hours exposure in ordinary temperature and humidity, Motors shall be approved as specified in item 7-1.</p>	
		位置 Position	电压 Volt	负荷 Load	温度 Temp	湿度 Humi	寿命 Life		
		轴水平 Horizon	额定 Rated	重量 Weight 振子	20°C	65%	200,000 Cycles		
6-2	低温放置 Low temp. exposure	温度 /Temperature : -40±2°C 时间 /Time : 96h							<p>在常温常湿下放置 2h 后, 马达应符合项 7-2 的要求。 After 2 hours exposure in ordinary temperature and humidity, Motors shall be approved as specified in item 7-2.</p>
6-3	高温放置 High temp. Exposure	温度 /Temperature : 80±2°C 时间 /Time : 96h							
6-4	湿度放置 Humidity exposure	温度 /Temperature : 40±2°C 湿度 /Humidity : 90~95%RH 放置时间 / Exposure time : 96h 无水气凝结/No condensation of moisture							
6-5	振动 Vibration	全振幅 /Displacement : 1.5mm (p-p) 频率 /Frequency : 10 to 55Hz 周期 /Period : 20min 范围内 (10~55~10Hz) /20 Minutes log sweep (10~55~10Hz) 方向 /Direction : x、y、z 时间 /Time : 每 2h /Each 2 hours							<p>测试结果应符合项 7-2 的要求。 After the test motors shall be approved as specified in item 7-2.</p>
6-6	自然跌落 Free fall	试验状态/Test state: 将马达固定在约 100 克 (包括马达本身) 的物体上, 落向水泥地面。 Set the motor to the approximately 100g (include the motor) weight of block drop the motor on the concrete floor. 高度 /Height : 1.5m 方向 /Direction : ±x. ±y. ±z 次数 /Number of times: 每个 方向 2 次 /Each 2 times							<p>测试结果应符合项 7-2 的要求。 After the test motors shall be approved as specified in item 7-2.</p>

6-7 热冲击
Heat stock test

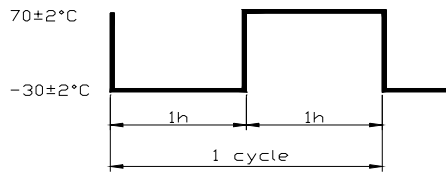

试验循环 /Test cycle :20 cycles

在常温常湿下放置 2h 后，马达应符合项 7-2 的要求。
After 2 hours exposure in ordinary temperature and humidity, Motors shall be approved as specified in item 7-2.

7. 要求/Requirements

项目/Item		判定基准 / Requirements	
7-1	表 A Table A	1) 额定转速/Rated speed 2) 额定电流/Rated current 3) 起动电压/Starting voltage	: 不低于初始值-30%; 不高于初始值+60% data-30% Initial Min data+60% Initial Max : 不大于初始值±30%/Initial data±30% max : 不大于 2.4V 直流电压 2.4V DC Max
7-2	表 B Table B	1) 额定转速/Rated speed 2) 额定电流/Rated current 3) 起动电压/Starting voltage	: 不大于初始值±30%/Initial data±30% Max : 不大于初始值±30%/Initial data±30% Max : 不大于 2.4V 直流电压 2.4V DC Max

8. 使用时注意事项/Matters to be paid attention to when using motor

8-1 电机在运输过程中应小心轻放，避免严重碰撞敲击引起的电机机身和性能受损。

(Please lay the motors carefully in transportation to avoid any serious damage to the motor body or its electric function because of collision.)

8-2 必须按照规格书的标准使用，否则会影响电机寿命。

(Please use the motor according to the instruction of this product specification, or else, it will be bad for motor's life.)

8-3 请在 6 个月内使用，请不要在高温、低温、高湿环境下存储。在使用和打开马达外包装时请避免水气凝结。

(Make arrangement to limit the storage period to 6 months or less. Please do not store motor in high temperature. Low temperature. high humidity environment. Condensation of atmosphere must be avoided in motor usage or opening the packaging of the motor.)

8-4 马达应适当的操作、储存和运转环境中均不可存在腐蚀性气体。例如： H_2S 、 SO_2 、 NO_2 、 CL_2 等。另外存储环境中不可有诸如硅、氰、甲醛水和苯酚等能放射出腐蚀性气体的物质，在电机的机械构造或装置中，如果存在腐蚀性气体，那么这会起引起马达不运转。

(For proper operation. storage and operating environment must not contain corrosive gases. For example H_2S . SO_2 . NO_2 . CL_2 . etc. In addition storage environment must not have materials that emit corrosive gases especially from silicon. cyanic. formalin and phenol group. In the mechanism or the set. existence of corrosive gases may cause no rotation in motor.)

8-5 请通电后不要长时间堵住机轴，并且马达转动时不要触碰振子。

(Please don't stall the shaft for a long time after powering, and not to touch the weight when motor is rotating.)

8-6 马达轴向间隙处不应有杂物（如颗粒、纤维物、头发、胶带、胶水等）

(There should be no sundries (such as grain, fibre, hair, small tape, glue etc.) in the shaft end play.)

9. 使用时注意事项/Matters to be paid attention to when using motor

9-1

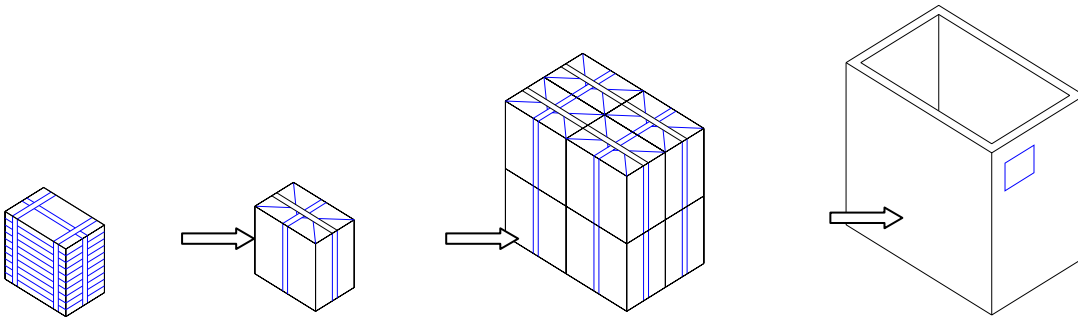

9-2. MECHANICAL DRAWING/机械图

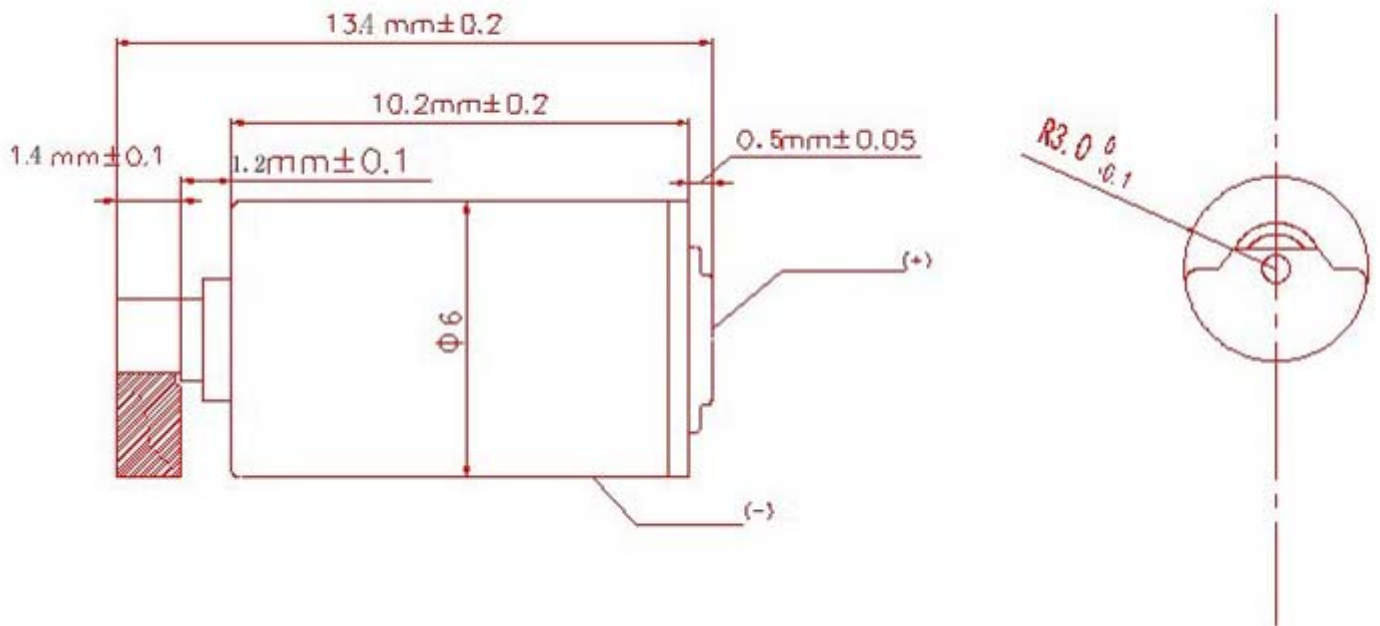

Figure 1 Motor Housing Configuration

图 1 电机外形结构图